

elite

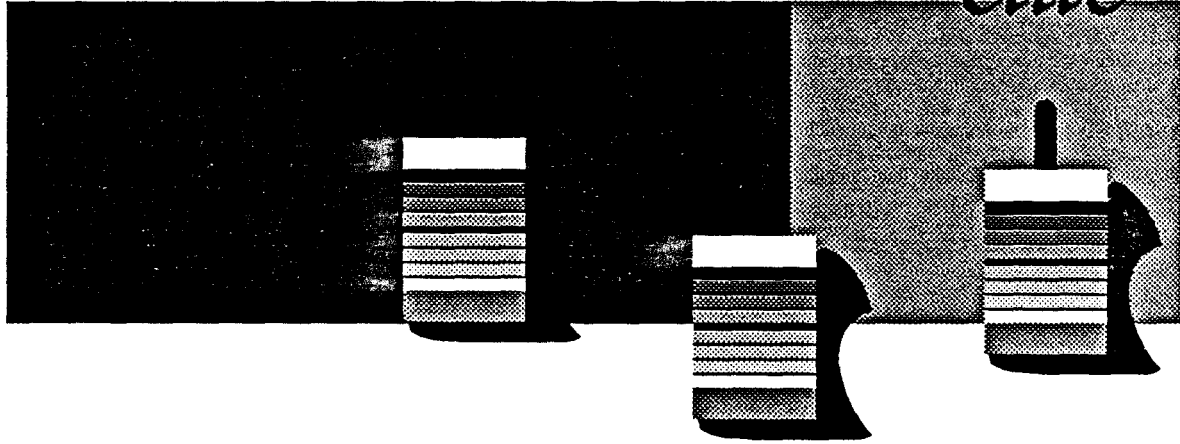

NEOTEK

WARNING!

This audio control console may potentially cause grave bodily harm if operated or serviced improperly. Feedback paths may inadvertently be created, causing the production of high level signals in the console or in associated equipment. These signals could cause equipment damage or produce acoustical signals of sufficiently high amplitude to cause hearing damage. Improper service or installation could expose persons to electrical shock, create a fire hazard, or could cause the console to produce erroneous signals that could damage associated equipment.

This console is intended to be operated and serviced only by trained professionals who are skilled in recording and technical service practices. Do not attempt to install, operate, or service this equipment unless you have taken all necessary precautions to prevent damage to persons and property. This manual does not contain instructions sufficient to permit this console to be installed, operated, or serviced safely.

The Serial Number of the console for which this manual was furnished is:

--	--	--	--	--	--	--	--

Please refer to this number when you contact your dealer for assistance with installation, service, or operation.

Please read the Neotek One-Year Limited Warranty which is reproduced elsewhere in this manual or which you should obtain from your dealer or from Neotek Corporation.

Table of contents

Volume One, Introduction and Operation

WARNING! Read this before operating the Elite

Neotek's Limited One-Year Warranty

Foreword and backward

Introduction

An Introduction to Signal Flow in the Elite

Input / Output Selection for the Dual Channels

Assignment of Filter, Insert, and Equalizer

Reconfiguration of the Signal Flow Architecture

Mute Logic Groups and In - Place Solo

Creation and Control of Non - VCA Subgroups

The Stereo Input Module

A Summary of Master Section Functions

Circuit Design Philosophy of the Elite

D D I, MIDI Direct, and Automation

Volume Two, Installation and Service

Installation Guide

Interpretation of Neotek Schematic Diagrams

Setting Internal Trimmer Controls

Schematic Diagrams and Service Illustrations

Input - Output Connector Pin Out Lists

Volume Three, Power Supply

Power Supply Installation and Operation

Power Supply Schematic Diagrams

Elite

Operator's guide

rev February 1988

Reflecting back upon the historical developments which lead up to the design of the Elite helps to understand the unique utility of the Elite console architecture.

A history of recording console design

In the days of mono and direct-to-two-track stereo recording, engineers monitored their work by listening to exactly the same mix as was being recorded. With the introduction of multitrack recording and the mixdown process, it was desirable to record to the multitrack at full levels and then adjust the combined balance of these tracks in a subsequent procedure. This meant that recording engineers needed a means to develop a monitoring mix independent of the multitrack recording levels; naturally some auxiliary sends from this mix would also be desirable. To meet these requirements, a small separate console was used. Soonafter, monitor mixing consoles were integrated into main consoles. The "split monitoring" console architecture was born.

The birth and death of split monitoring

As the multitrack recording process became more complex, split consoles became more elaborate, more cumbersome, and more redundant. For a time, their limitations were represented as features (always a marketing goal) so that the *requirement* of needing more than one operator was touted as the *desireability* of allowing more than one operator. Time marches on, however, and the increasingly complex multitrack recording process has relegated large split consoles to the status of the brontosaurus. All new large console designs have abandoned the classic split architecture.

And then in-line monitoring

Next, it was realized that a great many console functions are redundant during the tracking process. If a monitor level control and some switching were added to each input module, those otherwise redundant functions could be used to develop the monitoring mix. Thus was born the "in-line monitoring" console, which made for a more efficient layout than the split monitoring approach. Credit for this innovation goes to Dan Flickinger, whose consoles of the late '60s influenced all subsequent designs. The complexity of multitrack recording continued to increase, however, and more switches and functions were added to the in-line design. Fader reverse, for example, was added so that VCA distortion from the automated main fader could be avoided by mixing on the small monitor fader; once again a liability became marketed as an asset. Ultimately, increasingly complex routing functions reached the point where intelligible designations became impossible; switches labeled PING, FLIP, FLOAT, T&G, and so forth proliferated on console front panels. Even the power of computer assisted switching was unable to accommodate the requirements that new instruments, new formats, and new artistic techniques were presenting to the recording industry in 1985.

Now for something completely different

When the engineers at Neotek sat down to create their next generation of console designs, all this history was weighing in their minds and they were aware of the limitations of popular multitrack consoles, which had been designed a few years previously and were already obsolete in terms of the requirements of contemporary music recording. Because Neotek makes custom consoles, our designers had been exposed to a wide variety of requests for special functions which leading musicians and engineers were discovering. We soon realized that to achieve the flexibility of signal flow needed by modern recording techniques, simple enhancement of existing console architectures would require the use of multi-pole switches with cryptic labels and with effects on things like echo sends which nobody would be able to comprehend. It had become clear that adding embellishments to the in-line console concept had reached its limit in meeting the developing demands of multitrack recording.

The Dual-Channel approach

In order to meet the seemingly contradictory requirements of flexibility and ease of operation, a new approach was essential. Neotek refers to this unique approach, first used on the Elite, as Dual Channel architecture. Thus, the signal flow system of the Elite was based on two distinct audio paths within each input module. These two paths are basically identical except for the mechanical length of their faders. For simplicity, the signal route with the longer, separately mounted fader is called the Fader path, and the one with the shorter fader is termed the Monitor path. These terms were chosen because of their familiarity, but in no way limit the uses of the two independent audio signal paths.

The design of the Elite was more than another rehash of old ideas with new cosmetics. To understand the capabilities of the Elite, it is helpful to consider its design objectives and the rationale of its solution to the problems of flexibility, higher performance demands, and increased sonic quality.

In the beginning

When Neotek's design engineers began the task of creating the next generation of Neotek consoles, they were well aware of the shortcomings which changes in recording processes and equipment had revealed in the performance of existing consoles. Popular consoles, including those of Neotek, had been designed four or five years earlier at a time when there were no MIDI virtual tracks from multiple synthesizer outputs, no digital recording, and very little audio for video post being done in recording studios. Engineers were just beginning to hot rod drum synths to bring out individual voices; consoles had never been required to have multiple inputs available or to provide adequate isolation between signals that had been created beyond the constraints of acoustic reality. Existing consoles had many flaws that were concealed by analog recording media and by the low frequency crossovers and high end rolloffs of cutting lathes. Digital recording had never revealed in excruciating detail the murderous things that consoles in all price ranges could do to audio, and what murderous things digitally synthesized tracks could do to console performance.

The impossible takes a little longer

Neotek manufactures custom consoles, so our engineers were able to draw upon the experience of meeting the functional requirements that progressive recording artists were developing. Neotek designers knew that high level, wide bandwidth synthesized sounds play havoc with ordinary op amp circuits and PC board layouts, so totally new topologies needed to be developed. Neotek had a well-established reputation for superlative sonic performance among esoteric classical CD labels, but our designers knew that even greater demands would be placed on future consoles. While existing Neotek consoles exceeded digital recorder performance in terms of noise, distortion, and bandwidth, it would not be easy to maintain this standard of performance when a great number of inputs were summed together. As of this writing, the average number of input modules in Elite consoles is over 40, 56 is not uncommon; in mixdown that's over 100 inputs without even considering effects returns, a far cry from the challenges facing the consoles of 1981.

Ready for digital before digital was ready

The requirements that digital recording places on consoles are not only reflected in performance specifications. Digital recording reveals and accentuates nuances of performance once disguised by analog tape machines and low resolution monitoring systems. Not only the noise level, but the spectral distribution of the noise becomes important to subjective satisfaction. High frequency artifacts from intermodulation or slew induced distortion are especially annoying, and poorly controlled low frequency response is faithfully reproduced as audio mire. And just because a digital recorder can reproduce a digital synthesizer doesn't mean a console with "pretty good" specifications won't choke the musicality out of both.

And ready for dolby SR, too

The impact of digital technology on audio has been so pervasive that today even musicians and consumers have ready access to 16-bit digital recording. Another unforeseen development which challenges console designs is the introduction of dolby SR, which combines the noise performance of digital recording with the musicality of analog tape. The design standards of the Elite were established with these challenges in mind, as two examples illustrate. A user reported that when the input to his Elite was 24 tracks of dolby SR, the mix noise dropped by 20 dB when the SR unit was turned off. In another case, a professional CD player was assigned to all multitrack buses of an Elite, which were then sent to the stereo mix; the output noise of the CD player between tracks or in pause mode was over 20 dB greater than the combined noise of the console's buses and faders. The Elite was designed to meet the demands of outstanding sonic performance as well as technical excellence.

Establishing the design requirements

From these observations and a dozen years of experience at the forefront of analog circuit and console system design, the engineers at Neotek established the following criteria for the next generation of Neotek consoles:

Dual channel input module architecture

The console should have a dual channel input module signal architecture that would allow the second channel to be used as an additional full-featured input channel as well as a monitor channel, effects master, subgroup fader, and other diverse functions.

Easily alterable architecture

The functional blocks of preamplifiers, filters, insert point, parametric equalizer, auxiliary sends, and output assignments should be freely configurable in either channel. Furthermore, the signal architecture of input modules should be individually modifiable so that the two input channels of each module could be used independently or in concert with each other. It would then be possible to easily create new as well as traditional signal control possibilities in different parts of the console.

Advanced circuit design

The circuit design, PC board layout, signal wiring, and grounding technologies used should accommodate existing and foreseeable requirements created by high density consoles, synthesized sound sources, and digital recording. It should offer the latest refinement of Neotek's highly regarded state variable equalizer. Above all, this new design should enhance Neotek's established reputation for superlative sonic quality and the highest technical performance specifications.

Interface to the modern world

Not only should the console be complete in its own internal logic control system, but it should offer easy installation of any contemporary automation system, including existing and proposed moving fader systems. It should provide for simple and effective means of control by video editors, computer controlled switchers, and by MIDI sequencers.

You guessed it

The Elite represents the successful achievement of these, as well as more traditional, design objectives. The discussions which follow highlight some of the features which resulted from the standards set forth at the inception of the Elite design effort.

An introduction to signal flow in the Elite

For those too impatient to read manuals, read this.

'Tis a joy to be simple

The details of each of the blocks in the Elite block diagram are discussed elsewhere, but in simplest form the two signal paths consist of only three blocks: an input selection switch, a fader, and an output selection switch. Input signals for each path are independently selected from among the microphone preamplifier (MIC), balanced line input (LINE), or the console's balanced multitrack bus output (BUS). In addition, the Monitor path can select for its source the output of the Fader path (BUS + MIC). There are only two possible outputs for the two signal paths: either to the main stereo buses through the main MIX PAN control and the logic-driven mute, or to the multitrack buses through the upper TRACK PAN control and TRACK MUTE switch. Normally the Fader path feeds the multitrack bus assignments and the Monitor path feeds the stereo mix, but the outputs of the two paths can be interchanged with the REV switch. (Note that this is not the same as 'fader reverse'.) The two channels each have their own pre-fader SOLO switch, polarity reversal (-Ø) switch, and full-wave peak-sensing peak LED, labeled by !.

'Tis a joy to be free

The remaining blocks of the Elite block diagram can be switched into either path, depending on the engineer's requirements. The sweep high pass filter, balanced insert point, and state variable multimode parametric equalizer each assign independently to either path and, unless assigned, have a hard-wire bypass so that all associated electronics are completely out of the audio paths. The six auxiliary sends also assign to either path, pre- or post- either fader.

In addition to the many possibilities for manipulation of the functional blocks (for example: what happens if you assign the insert point to both paths? answer: something very useful) there are additional provisions to change the signal flow within Elite input modules which offer even more flexibility and signal routing control.

Tracking: don't push any switches

Mixing: push Fader LINE and REV

It has always been a self-imposed requirement of Neotek console designs that the operator doesn't have to do something in order to make the console work. Thus the design of the Elite is such that when none of the reconfiguring switches is pushed, the console is set up in the normal signal flow for recording, tracking, or overdubbing. The microphone preamp feeds the Fader which feeds any of the multitrack buses, and the line input (on which appears the return from the multitrack tape machine) feeds the Monitor fader which then feeds the main stereo mix heard on the control room speakers.

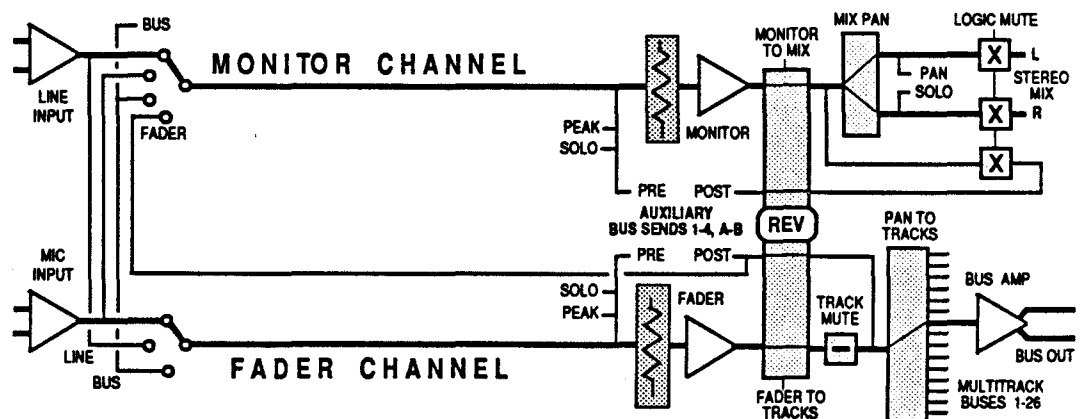

Simplified block diagram of the Elite input module, no SOURCE switches pressed, in tracking mode

Input / output selection for the dual channels

The basic architecture of the Elite is based on two separate signal paths within each input module. These paths have independently selectable inputs and outputs which, in combination with other signal routing provisions, results in tremendous power and flexibility. It also offers numerous ways to create feedback paths, however, so the prudent operator will study the potentialities with care.

Fader channel input selections

With neither of the FADER SOURCE switches (LINE, BUS) pushed, the input signal to the Fader channel is taken from the microphone preamplifier. This is the normal mode for tracking. For mixing, pushing the LINE switch selects the input source which is connected, through normalised jacks in the patch bay, to the module's balanced line input amplifier. This would normally be the correspondingly numbered output of the multitrack tape machine. The line inputs of modules which are not required for the multitrack machine may be used as echo returns connected to external processors or used to input other line level signal sources.

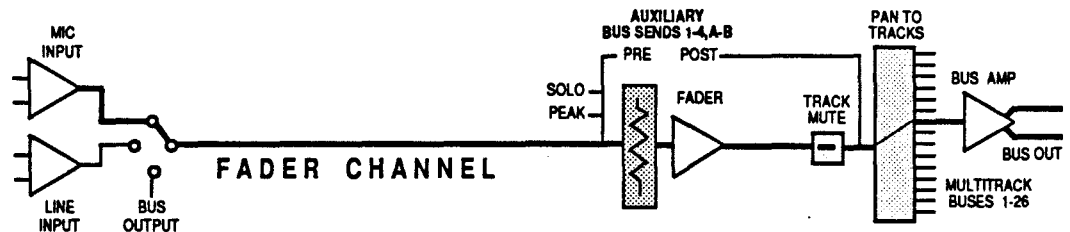

Why provide a BUS selection?

The provision to select the output of the module's multitrack combining amp with the BUS switch allows monitoring from the console outputs. It also allows either fader to be used as a master level control for all signals assigned to that module's bus. The Fader then becomes a group master and in particular modules 25 and 26 return signals assigned to their buses to the main stereo mix. The purpose of providing the extra 25-26 buses is to permit both faders to simultaneously access two independent stereo buses, which may be combined if required. This facility could be used for a mix-minus, separate TV mix, and so forth, or it could be used to develop a stereo submix from numerous Monitor faders which are being used to return effects or synthesizer virtual tracks to the console.

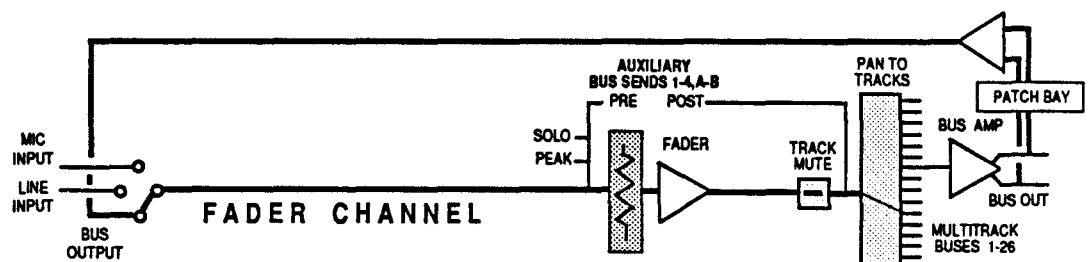

But beware of creating feedback paths

Note that if a module is assigned to its own bus, selecting that bus as its input creates a feedback path and will cause oscillation. This can occur if both source switches are pressed (to get FADER for the Monitor source) and the wrong switch is released first, leaving only BUS pressed. This won't harm the console, but it could damage loudspeakers, headphones on the foldback system, or engineer's nerves.

If you need another balanced line input

The balanced output of the bus amp is returned from the patch bay to the module by a differential input amplifier. This means that patching a signal into the patch bay jack labeled TAPE INPUT sends the signal to the tape machine input (unused during mixing) but more importantly the patched signal will also appear at the Fader or Monitor BUS switches. This provides an additional balanced line input to the module. Including the padded mic preamp but excluding the insert return, there are then three available line level balanced inputs accessible to either fader path.

Monitor fader path input selections

Input source selection to the Monitor fader path is essentially identical to that for the main Fader except that, with no source selection switches pressed, the input to the Monitor path is the module's balanced line input. Again, this is the standard condition for tracking or overdubbing. This means that the two faders can be used interchangeably, depending on what process the engineer deems most important. For example, a monitor mix can be developed on the main Faders during an overdub session so that when the session is complete a rough mix already exists on the faders that will be used for the mixdown. By selecting BUS, a monitoring mix can be taken off the console outputs instead of the tape machine returns. The Monitor faders can be used as additional line returns, for synthesizers or effects returns, thus doubling the number of inputs during a mixing session. The Monitor path can also serve as a subgroup master, or as a mic input for a last minute overdub after the rest of the console has been set up for a final mix.

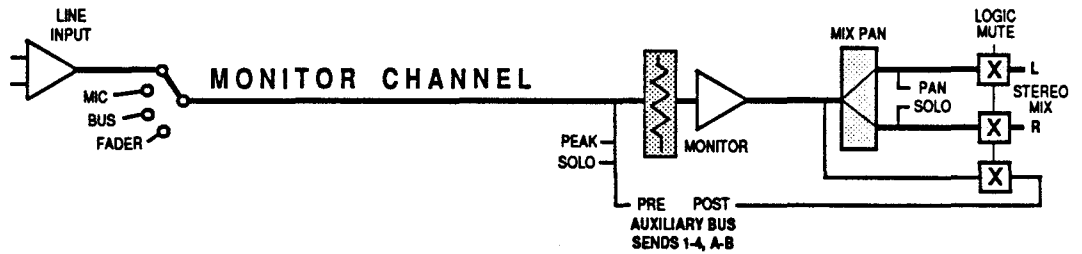

The REV switch

There are two outputs to which the signals in the Fader or Monitor channels can be sent. These are to the multitrack assignments through the TRACK MUTE and TRACK PAN, and to the main stereo mix buses through the MIX PAN and logic controlled mix MUTE. With two possible choices, a REVERSE switch provides complete control of the output of the dual channels. This switch is labeled on the front panel of the input module, just above the mix PAN control, as



When pressed, this switch simply reverses the outputs of the two channels. Operating with the REV switch, as well as the Fader LINE switch, pressed is the normal mode for mixing. The Monitor fader remains available for a variety of other uses. Post-fader auxiliary sends will remain post-fader after pressing REV, and post-monitor sends will continue to follow the monitor fader. However, these sends will be affected by the expected and appropriate mute switch which becomes associated with each fader. This approach, an important part of the dual channel design, is much more powerful than the ordinary fader reverse switching of older console architectures.

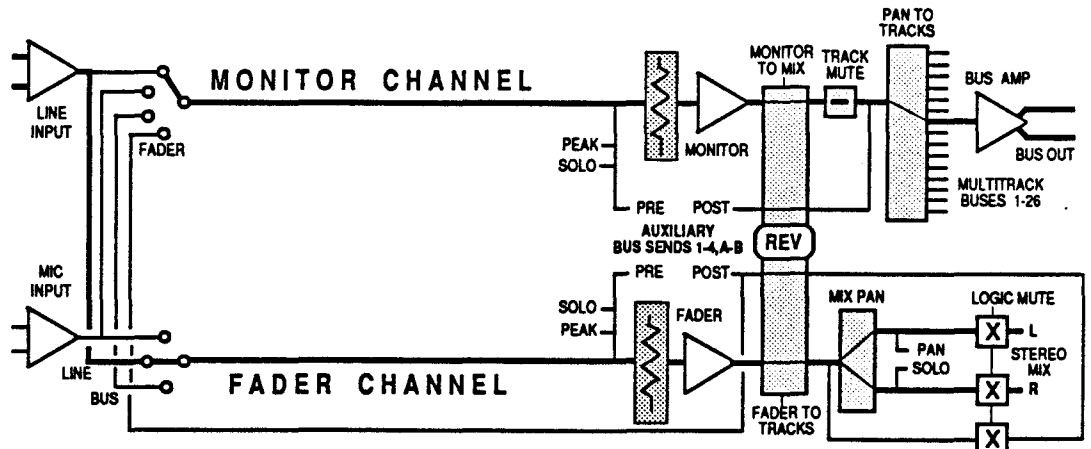

Signal flow in the Elite input module with REV and Fader LINE pressed, normal mixing mode

The Fader as Monitor source

Provision to select the output of the Fader channel as the source for the Monitor fader (by pressing both its MIC and BUS switches simultaneously) allows the Monitor fader to become a convenient local master for selected effects sends. These sends would be post-Fader as well as post-Monitor and could be any of the six auxiliary sends as well as any of the multitrack buses. This provides slide fader level control, phase reverse, and SOLO for a total of 32 separate echo send buses from the Fader channel. In another application, if buses 25 and 26 are thought of as a second stereo bus, the Monitor faders could be used to create a second stereo mix on 25-26 which would be subordinated to the main stereo mix from the Faders.

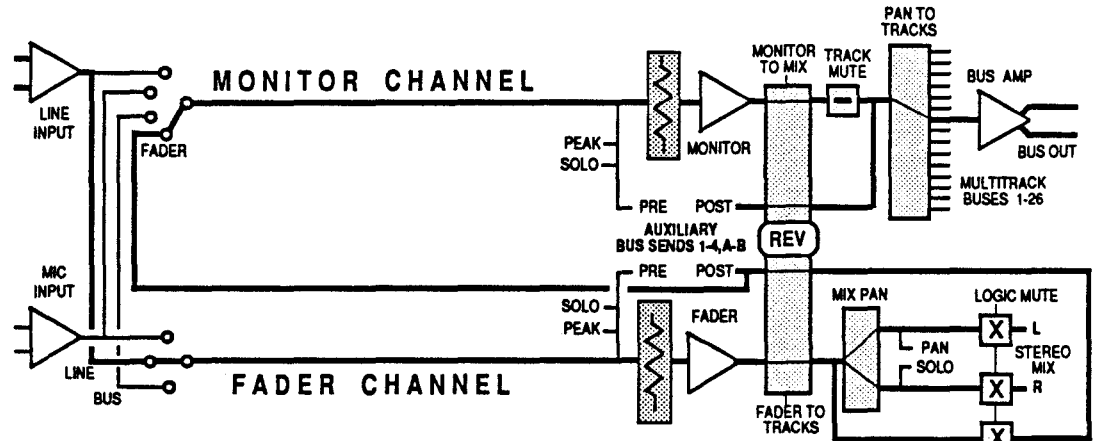

Signal flow in the Elite input module, using REV and the Monitor fader as an echo send master when mixing

Mix and match

None of the applications that have been discussed are mutually exclusive. In typical situations, some of a console's faders will be serving traditional applications, others will be used in unique ways to make the engineer's tasks easier in each variety of session. The examples offered are intended to be suggestive, not exhaustive. Careful attention has been given to matters of isolation, noise buildup, phase compatibility, and so forth, so that engineers are free to modify the console architecture according to their own creative requirements.

There's more

The Elite implementation of dual channel architecture allows the operator to reconfigure the blocks of the console's input module block diagram using easily understood switches. This means that all of the routing flexibility of both split and in-line consoles, as well a great deal more that is beyond the reach of either, is now readily available at the operator's fingertips. The console operator can literally select whatever architecture the application requires, in all or in only part of the console, without having to resort to patch cords or mystery switches and without having to search for lost echo sends that suddenly become lost in the patch bay.

Assignment of the high pass filter, insert point, and equalizer

The functional elements of input modules include the high pass filter, insertion point, equalizer, and auxiliary sends. In many applications, particularly when the second channels of input modules are used for producing the monitoring mix, leaving the functional elements of input modules associated only with the Fader would be undesirable or redundant. Allowing them to be assigned to either path not only reduces this redundancy, but also permits operators to easily configure unique architectures for specific applications.

Basic configurations of the Dual Channel input module

As mentioned in previous sections, when none of the switches on an Elite input module are pressed the module is set up for tracking or overdubbing. The microphone preamp feeds the Fader which feeds the multitrack assignments; the Monitor fader input is taken from the module's Line Input (which is fed from either the input or sync output of the associated tape machine channel, depending on its mode) and the Monitor fader output is panned to the stereo mix through the logic mute. To set up an input module to the simplest mixing configuration the LINE switch is pressed for FADER SOURCE and the output of the Fader is sent to the stereo mix by pressing the REV switch. In neither tracking nor mixing modes are any of the other unassigned functional elements in either signal path.

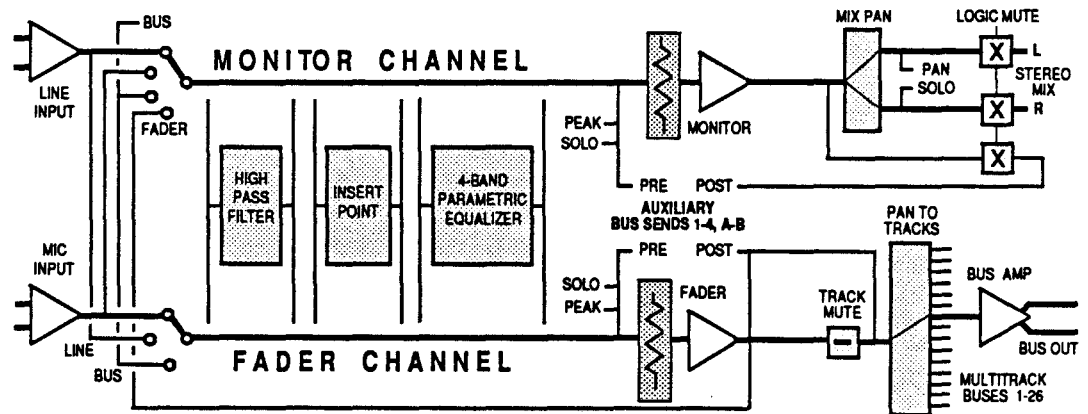

Simplified block diagram of the Elite input module, no SOURCE switches pressed, in tracking mode

The high pass filter

The high pass filter of the Elite is a special two-pole design which is strictly minimum phase. It has a wide tuning range, made possible in part by a custom control, to make it useable in many applications. Because the unfiltered frequency response of the Elite extends well below audibility and even reproducibility in order to preserve phase coherence in low frequency signals, the high pass filter's characteristic frequency begins at 20Hz and is sweepable to 375 Hz.

The insert point

The insertion point of the Elite Input Module provides an output at full signal level in the patch bay. It is connected to the normalised pins of a balanced return input. In keeping with the minimum path design approach of the Elite, the balancing amp is completely bypassed and out of any circuit if the insert point is not assigned to either the Fader or Monitor paths. The send signal is always available in the bay, however, and follows the Fader input selection unless the insert point is assigned to the Monitor fader signal path.

The equalizer

The Elite equalizer is the most recent and most refined version of the multimode state variable parametric topology which has been highly regarded in previous Neotek consoles. It employs full state variable circuit design, rather than the common Wein bridge circuit, to eliminate interactions between frequency, boost/cut, and bandwidth functions and to achieve maximum sonic quality. This topology also results in greatly reduced sensitivity to control tolerances, keeps the noise floor

The equalizer, continued

very low, and allows complete control of internal node signal amplitudes. When the boost/cut knob (the upper one of each of the four concentric pairs) is pulled upward on the high and low bands, the response mode changes from peak/dip to shelving. In the shelving mode Neotek design engineers have chosen a Bessel response, rather than the more common Butterworth, again for reasons of improved sonic quality. Full tuning range is maintained in the shelving modes, and the boost/cut setting is not affected. The two mid bands similarly switch to narrow bandwidth, a bit wider than third octave. Again, no change of frequency or amplitude settings results from changing modes. The high band frequency range includes 20kHz because we have found that a touch of boost here improves the sound of material after multiple generations. The high mid band reaches 8kHz, allowing the high band to be used a sweep low pass filter while retaining high frequency control. Similarly, the low mid reaches to 50Hz for use in conjunction with the low band, which extends from 20Hz to 400Hz. Features like these, in combination with well-chosen bandwidths, allow the Elite to provide the most powerful and musical equalizer of any current console. With it, engineers are no longer tempted to patch in external EQ, even powerful GML parametrics or tubed Pultecs, in order to achieve the frequency control and smoothness they require.

Assignment of the high pass filter, insert point, and equalizer

These three functional elements are independently assignable to either the Fader or Monitor signal paths. The sequence in which the audio flows through them is always the same: high pass, insert, then equalizer. One common tracking/recording/overdubbing configuration might find the high pass and insert assigned to the Fader path with a compressor patched into the insert point and the high pass filter set to remove low frequency pumping. The microphone would be recorded on the multitrack without EQ, but with the equalizer assigned to the Monitor path the console operator could get an idea of the equalized sound of the final mix.

Unlimited applications

A more unusual application example is a mixing set up with the MONITOR SOURCE selected to be the Fader output (by pressing both the BUS and MIC switches). Auxiliary buses which are left switched in post-Monitor mode will have the Monitor fader as their master. If the insert point is switched to the Monitor path and a delay processor is patched into the channel, the Monitor fader will control the amount of delayed echo send. Undelayed echo can be sent directly from the Fader by switching some sends post-Fader. Since provisions of the cue mixer in the master section allow auxiliary buses to be combined, non-delayed echo sends from the Fader and delayed echo sends from the Monitor could be apportioned in the same chamber with different levels from each input module configured in this way. In a similar manner, some echo sends could be equalized differently from the main Fader signal. Remember also that the multitrack buses are available to provide an additional 26 mono or 13 stereo effects buses, controllable with the Monitor fader as their level control while the main Fader feeds the mix and other post-fader effects buses.

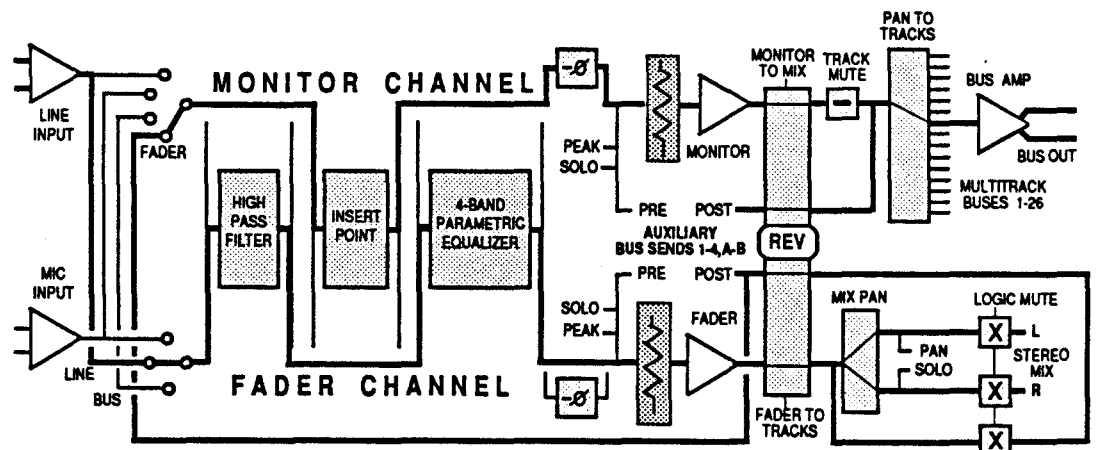

Signal flow in the Elite input module, using REV and the Monitor fader as an echo send master when mixing; the Monitor channel has a processor inserted and is polarity inverted, the Fader channel uses the high pass filter and EQ

*Assignment of the
auxiliary buses*

The six auxiliary buses switch in pairs so that their sources are either pre- or post- either the main Fader or the Monitor fader. In their unpressed switch mode they are set up for normal tracking: Aux A-B, a panned pair, are sourced pre-Monitor and Aux 1-2 and 3-4 are sourced post-Monitor fader. This provision allows Aux A-B to be used to develop a stereo cue (headphone) mix and for 1-2 and 3-4 to be used as echo sends for the monitoring mix. Other switched arrangements should be obvious. The post-auxiliary sends are affected by the mute switches, mix or tracks, that apply to the fader which they are switched to follow, and they continue to do this if the REV switch is pressed.

*Pre- and post-fader
echo sends*

Provision is made in the master section to use the headphone cue mixer as a means of combining auxiliary buses into the same output signal. One application of this, other than, and in competition with, its application to develop cue mixes, is to combine auxiliary bus sends into the same chamber feed. For example, it is sometimes desirable to use both pre- and post-fader echo with certain signals, such as horns or strings, so that when faded in the mix they appear to recede as opposed to merely get smaller. The Elite permits this to be done on desired input modules by selecting the appropriate auxiliary sends to be sourced both pre- and post-Fader (or Monitor, for that matter) and then use the cue mixer to combine the signals being sent to the chamber. The Monitor fader can be also be used as a convenient pre-Fader auxiliary bus master if the Fader channel signal is Y-ed before the Fader, as described in the following section, and the auxiliary buses which are wanted to be pre-Fader are then switched post-Monitor fader. This does not interfere with the use of the buses or the chamber in traditional ways on other input modules.

Reconfiguration of the signal flow architecture

The complex of signal flow possibilities, which is termed the architecture of audio consoles, is constantly challenged by new recording methods and by recording engineers who seem to invent bizarre requirements without end. The Elite offers unique solutions to these problems.

Splitting the input signal; the fivefold way

The input signal to an Elite input module, whether it comes through the line or microphone input, can be split (Y-ed) to the Fader or Monitor paths in numerous ways, depending on the operator's requirements. There are six points in the module architecture where the signal can be Y-ed; patch cords are unnecessary. The outputs of the two paths, to multitrack buses or to the main stereo mix, can be reversed with the REV switch, giving the architecture of the Elite unprecedented flexibility and power.

The first

The first point at which the input signal can be split is immediately after its associated input amplifier, mic or line. This is done by selecting the same source for both Fader and Monitor paths. This would allow, for example, a single source, such as a microphone, to be in two completely independent stereo mixes. Independent assignability of functional elements allows EQ on one mix and compression on the other, with no interactions. Auxiliary sends are independently switchable to both paths, so both mixes could have independent echo mixes as well.

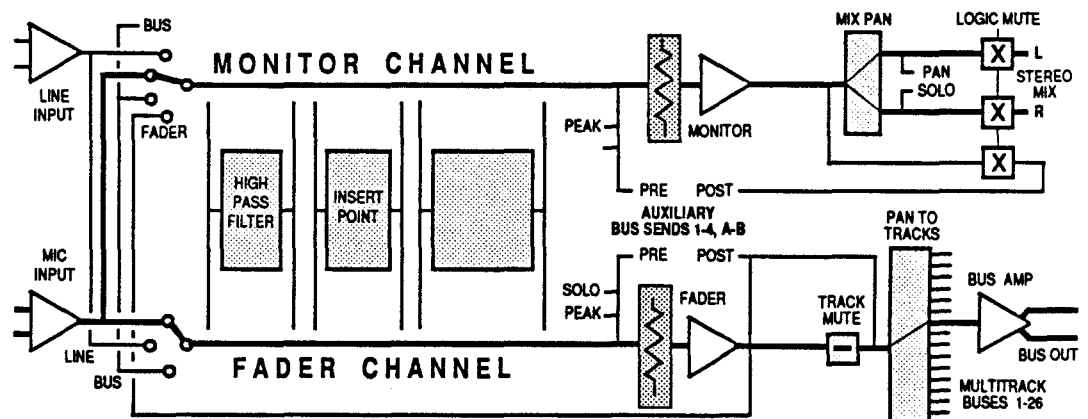

The second

The second point at which input source signals can be Y-ed between the Fader and Monitor paths is achieved by simultaneously assigning the high pass filter to both paths. Since the high pass filter is a mono circuit and has only a single output, it is clear that if it is assigned to both paths its output must then feed both faders. When any of the functional elements is assigned to both paths, the source switches of the Fader path determines which input source signal is selected. After this Y-ed point the insert point, equalizer, and auxiliary sends are freely assignable to either path.

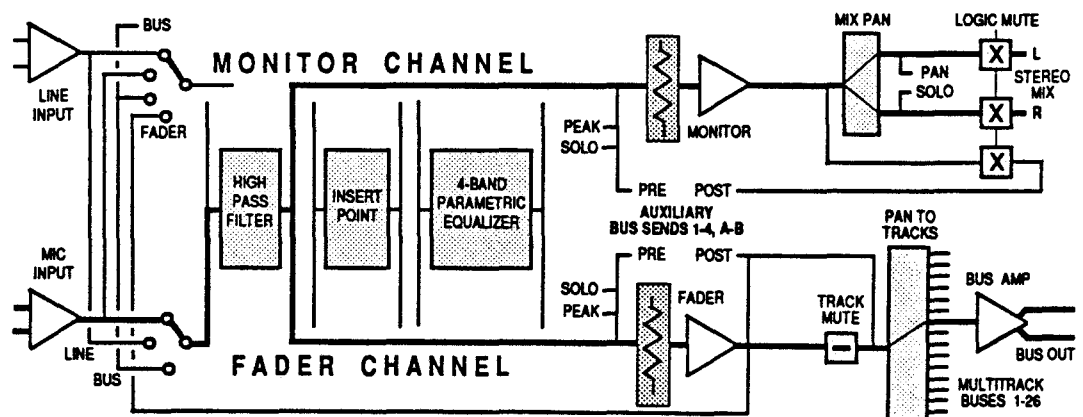

The third

The next point in the signal flow architecture at which the input signal can be Y-ed is achieved by assigning the insert point to both the Fader and Monitor paths. By the previous logic, the output of the balanced insert point return will feed both paths and the Fader source selection will prevail. The equalizer and auxiliary sends are still freely assignable to either path, but the high pass filter must be assigned to the Fader path to have an effect. If this is beginning to sound unmanageable, take a highlighter to a copy of the block diagram and satisfy yourself that the most logical effect does indeed take place.

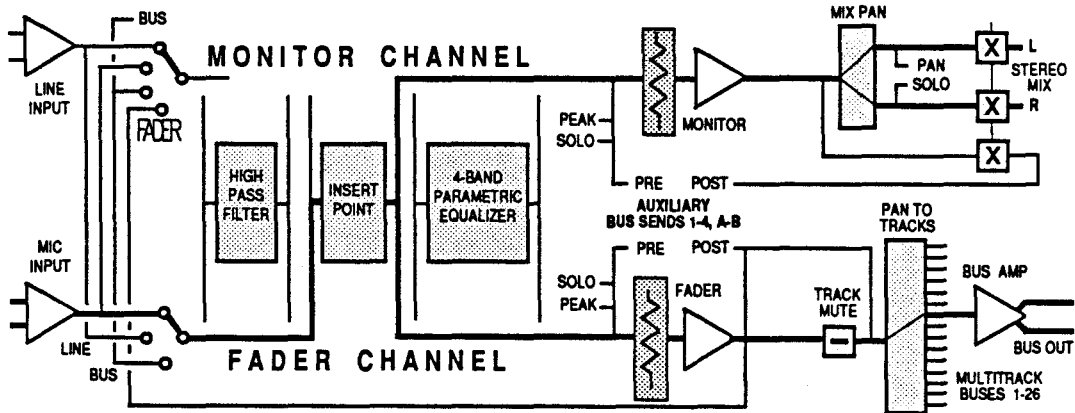

The fourth

For those who have followed this far, the next Y point is obvious: assign the equalizer to both Fader and Monitor. Again, with the Fader input selection taking precedence, the high pass filter and insert point must be assigned to the Fader path in order to affect the signal.

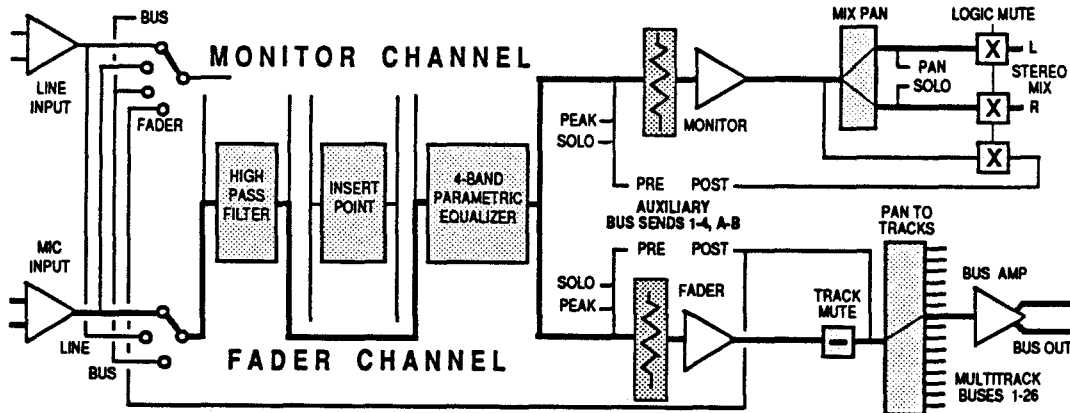

The fifth

The fifth point in the signal flow architecture at which the same input signal can be split to the Fader and Monitor paths has been mentioned previously. It is achieved by selecting the Fader output for the Monitor input source by pressing both the Monitor MIC and BUS switches simultaneously. In this case, the high pass filter, insert point, and equalizer must be assigned to the Fader path, and the Monitor signal will be effected by the Fader (ie, it will be post-Fader). The auxiliary sends are still freely assignable pre- or post- either fader. As in every preceding case, the outputs of the two faders can be reversed with the REV switch, adding to the tremendous control which the Elite architecture provides. This signal flow diagram was shown on Page 7 and is shown again below.

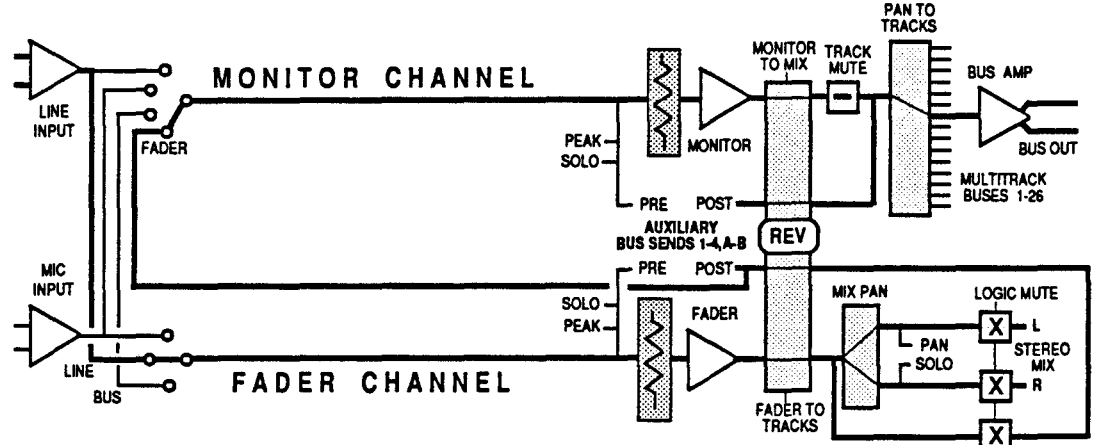

Signal flow in the Elite input module, using REV and the Monitor fader as an echo send master when mixing

The 25th and 26th

The Elite was made a twenty-six bus console in order to conveniently provide for a second stereo bus which would be accessible to whichever fader was not driving the main stereo mix. Providing the facility for the input signal to be split to both paths and providing for a mix of identical or independent processing and effects sends for each path means that the operator can develop two stereo mixes in a great variety of ways to suit every purpose. Remember also that each input module or group of input modules in the console can be configured independently of others, so the possibilities are virtually limitless. The utility is not only that this process requires only front panel controls and eliminates tons of patch cords, wasted time, and lost signals, but that in practice it is easily understood and reconfigured for future sessions.

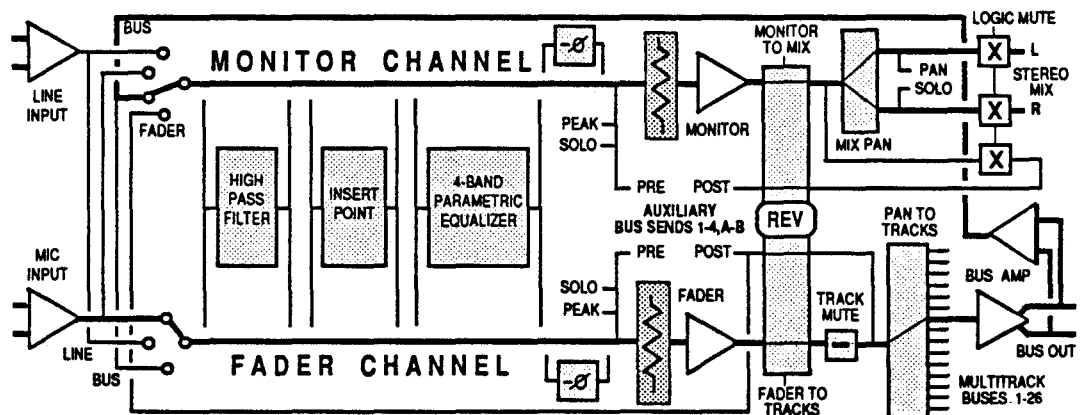

It should also be kept in mind that the circuit design, PC board layout, and signal shielding and grounding of the Elite were designed so that the unusual signal routing capability of the console would not be compromised by build up of annoying crosstalk and noise. Such problems are the downfall of older console designs when they are attacked with patch cords in attempts to achieve the flexibility that contemporary music requires. Also keep in mind that these reconfiguration possibilities are entirely optional, and that the console is in its straightforward recording configuration when none of the switches are pressed.

Mute logic groups, solo, and in-place solo

After mixing functions, the most important convenience features which a console provides are grouping functions. The most useful of these is provision to group the individual channel mutes and then to manipulate those groups from master controls. The Elite provides elaborate and comprehensive facilities based on its provisions for grouping input channel mutes.

Logic mute functions

In order to allow for grouping of mutes, the mutes themselves must be logic controlled. The Elite uses the most recent version of Neotek's FET mute circuit, in which discrete FETs are driven in voltage control mode by CMOS circuits operating from a secondary high voltage power supply. The FET mute/on action is ramped, DC isolated, and totally silent even with low frequency audio signals, unlike relay mutes which cause snaps as the result of abruptly chopping the signal. The entire console can be simultaneously muted without clicks or pops. Furthermore, the Neotek circuit achieves attenuation that is as good or better than relays, contributes no noise or sonic coloration the way CMOS IC switches do, does not require an amplifier in the signal path, and offers solid state reliability as opposed to the electromechanical unreliability of relays. Lastly, the Neotek Elite mute design achieves its high level of performance while muting in a manner that removes inputs from the stereo bus rather than shunting the bus to ground. This means that the stereo mix noise decreases when channels are muted as opposed to conventional designs in which the noise remains constant and therefore increases with respect to the relatively decreasing level of the signals remaining unmuted.

Mute groups

If a master section function puts a mute logic signal on any of the Elite's three mute logic buses, all inputs assigned to that bus will have their panned inputs to the main stereo bus muted along with all their post-fader auxiliary sends. Elite input modules have two switches, labeled A and B, which allow them to be assigned to the A, B, or C (by pressing both switches) mute groups. With neither switch pushed the channel is in a local mode and will be unaffected by master mute logic commands. Since the master functions provide for more than one logic bus to function upon a single master command, the three mute groups can themselves be grouped. This is approximately equivalent to assigning certain input modules to more than one mute group at a time.

Group mutes

The most basic use of the mute groups and master functions is simply to press one of master switches labeled MUTE A, MUTE B, or MUTE C. This will cause all channels assigned to that bus to mute and the associated LEDs on those channels will light. A fourth switch, labeled MUTE ALL, simply makes it easier to mute all three groups exactly simultaneously. Input modules can be taken in or out of mute groups without regard to the status of the group and they will immediately assume whatever status applies, on or mute. To turn on muted groups, release the appropriate master switches. This is most easily done by pressing them down slightly to release the mechanism and then completely releasing pressure on the switch to cause the unmute action. Note that additional flexibility is possible by using the MUTE ALL switch to simultaneously mute all groups, then press each MUTE A, B, C switch, release MUTE ALL, and then release each group switch individually at the appropriate instant.

In-Place Solo

The in-place solo provision is an exclusive mute function. That means that a channel that is in-place solo will cause all other channels to be muted. Enabling the in-place mode from the master section of the console causes the mode of the Input Module Mix Pan SOLO switches to be changed from their normal solo action that affects the monitor mix only. When a pan solo is then pressed, every other channel that is assigned to an enabled mute group will be muted and the in-place soloed channel or channels become unmuted. This action effects the main stereo mix, so it cannot be used when this mix is being recorded. Since it leaves the in-place soloed channel on in the stereo mix and sending signals from its auxiliary buses, it achieves panned solo with echo (wet solo) to allow critical setting of EQ, panning, and effects for the soloed channel or channels.

*Setting up the
in-place solo
mode*

Since the same input module switch, the one labeled Mix Pan SOLO, that is used for normal, non-mute, stereo solo is also used for in-place solo, master section switches determine which mode will occur. This is done by designating which mute groups will be affected. The in-place programming switches on the Stereo Master module are labeled IN-PLACE ENABLE, PAN SOLO WILL MUTE: GROUP A, GROUP B, GROUP C. If one or more of these three switches has been latched, pressing a Mix Pan SOLO switch on any input module will cause an in-place mode action in which all inputs assigned to the designated A, B, and/or C mute groups will be muted, except for channels whose Mix Pan SOLO switches are pressed. Those channels will become unmuted. If none of these three master switches is latched, pressing a Mix Pan SOLO switch will just cause an ordinary stereo solo, which is explained below. If a number of input modules have their Mix Pan SOLO switches pressed and the console is in in-place solo mode, the rest of the unmuted inputs can be brought into the stereo mix simultaneously by releasing the master in-place programming switches, which cancels the in-place mode and therefore cancels the resulting master mute commands.

In-place solo groups

The utility in permitting the operator to determine which mute groups will be muted by an in-place solo is severalfold. The simplest use allows an additional means of controlling mute groups during an actual recorded mix. More importantly, however, is its use for certain input modules which are used as effects returns. It would make no sense for these modules to be muted during an in-place solo, for then the soloed channel would not be heard with its returned echo or other effects. In such a case, the channels being used for effects returns should be left in their local mode (unassigned to mute groups) or perhaps be assigned to Mute Group C so as to give master mute control over all such effects return modules. In this case the in-place set up would be to latch PAN SOLO WILL MUTE: GROUP A and GROUP B, but not GROUP C. Mute Group C would remain functional and under control of its master mute switch, but it would not take part in in-place solo actions.

*Except for the
exceptions*

Some solo switches do not cause in-place solo action under any circumstances. This allows them to be used in their normal solo mode while mute-group-assigned input modules are set up to cause in-place solo. Such switches are the pre-fader mono SOLO switches on the Fader and Monitor paths of input modules, and SOLO switches on master functions such as the Auxiliary Bus Masters and Cue Masters. It would, of course, make no sense for the Effects Return channels to cause in-place solo; that would mute the sends that drive them. Similarly, Stereo Input modules, often used as returns for stereo effects processors, are provided with a switch, labeled IN-PLACE DISABLE, so that when used as stereo effects returns their stereo SOLO will not actuate the in-place mode. The same reasoning applies when Stereo Input modules are used for

Simple solo

For reference, the normal solo mentioned above refers to an action that effects only the monitoring signal in the control room, not the main stereo mix. The soloed signal simply replaces the monitor mix when its SOLO switch is pressed. This means, however, that the soloed signal will be heard without returned echo (dry solo). Simultaneously soloing an echo return would in most cases be an ineffective solution, since the chamber would be driven from several other sends in addition to those of the soloed channel. The Mix Pan SOLO from input modules, in the non-in-place mode, is true stereo taken from the module's Mix Pan pot. Other stereo signals in the console also solo in stereo, and the Auxiliary Bus masters solo left and right in odd-even pairs. The mono SOLOs of Input modules cause the monitor mix to go into mono and illuminate the MONO LED as a reminder.

*And not so simple
solo*

One additional provision of the Elite solo system is the SOLO LOCKOUT switch. This is useful, for example, when a number of inputs are soloed together, such as a drum group within the main mix. If frequent reference to this group is made through the solo function there results the need to press and release a lot of SOLO switches and spend a lot of time with only part of the group soloed. To avoid the problem, the operator can disable the effects of all normal mode SOLO switches by pressing the master SOLO LOCKOUT switch. Then any SOLO switches that are pressed will only cause the SOLO LED to come on at half intensity and the monitor mix will not be effected. Releasing the SOLO LOCKOUT switch allows the solo effect to occur, bringing all soloed signals into the monitor mix simultaneously. Pressing the SOLO LOCKOUT switch again will un-solo the entire group at once.

Creation and control of non-VCA subgroups

One of the capabilities which provides additional control to console operators is the ability to create and control audio groups. In many console designs this is relegated to a VCA grouping function that is part of an automation system. The Elite allows easy installation of any popular automation system, including moving fader systems. In addition, however, it also provides powerful provisions for audio level grouping which do not depend on automation systems or fader VCAs. There are advantages to both approaches.

Subgrouping at the simplest level

The simplest means of subgrouping on any console is to assign input modules to be grouped to one or a stereo pair of the multitrack buses. The output of the bus is then patched into the line input of an input module being used as the group master. The Elite makes this even easier, because both of the audio paths on each input module can directly access the corresponding multitrack bus output by simply pressing the appropriate BUS switch. For example, the short faders are free to be used as group masters when the long faders are involved in producing the main mix.

Is not so simple

Combining signals is only one part of creating useful subgroups; it is also necessary to remove the signal from its normal target, which is generally the main stereo mix, so that it is sent only to its group. If the channel MUTE switch were used to kill the stereo mix feed, this would also mute the post-Fader auxiliary sends. That would prevent creating individual echo send levels from each group member. While sending overall group echo from the group master might be acceptable for certain groups, such as strings or chorus, it would probably be unacceptable for, say, drums.

Except on the Elite

The Elite offers a unique solution to this problem with the switch on each Input Module labeled SUB 1-16. When this switch is pressed, the normal feed from the channel Mix Pan pot is removed from the main stereo mix and made available on the first sixteen multitrack assignment switches. This allows for creating sixteen mono or eight stereo groups in the console. The module's Mix MUTE switch, Mix Pan SOLO, and other functions are still available and the MUTE switch still controls the post-Fader echo sends. The difference is only that the stereo output of the module goes to some of the multitrack buses for grouping instead of directly to the stereo mix.

One other application of this function other than subgrouping is to provide the power of the module's logic mute to the multitrack assignments. Normally the TRACK MUTE switch in the assignment section accommodates this function, but the operator has the option of using the SUB 1-16 switch to provide logic muting to the first sixteen multitrack buses.

Echo for the group

The reason that the SUB 1-16 switch works on only the first sixteen buses is to allow the remaining ten to be used for effects buses solely for the subgroups that are created on 1-16. Subgroups are often created late in the mixing process, when the main six effects buses already have carefully developed mixes on them. The SUB 1-16 approach of the Elite doesn't require a massive echo mix reorganization just to create subgroups with echo.

The rub

The consideration with any method of creating non-VCA groups which have individual, in contrast to group master, echo mixes is that a separate chamber is required for each group. This is because lowering the group master fader would not fade the echo sends from group members, so the group echo sends would remain unfaded in the chamber and in the main stereo mix. It is possible to use a single Stereo Input Module to control a mono submix on one side and the output of the bus used for group echo on the other, bringing the echo bus into the main chamber feed using echo sends from the Stereo Input Module, but this is cumbersome. Similarly, a pair of adjacent Input modules offer a weak solution for a stereo group with stereo echo. In modern studios the requirement of a separate chamber is usually not a problem because separate chambers, or other processors, are inexpensive and would be used in many cases anyway. The output of the multitrack bus used for group effects would be patched into the separate effects processor input; again, the Elite offers unique utility because there are gain controls on each multitrack bus output, making it easier for the operator to use them as effects buses. The return from the group's chamber would be brought into the group with another fader, such as an unused Monitor fader, which would be assigned to the group's bus and would therefore also be controlled by the group's master fader.

The advantage

The utility which non-VCA groups have over fader-control groups (whether the faders are VCA functions, servo driven, or otherwise controlled by master functions) is that the group actually exists as a combined audio signal. This means that it can be compressed or limited or processed by other means. This is not possible with VCA-type groups of course, because no group audio signal actually exists.

The utility

The nature of non-VCA groups ideally suits them for groups, such as strings, horns, or chorus, which might do well with overall echo and which might benefit from a certain amount of compression or overall processing, such as doubling or chorus effects. Such groups are very easy to put together on the Elite and, because of the availability of many extra faders, can add convenience without taking facilities from her chores. If more complex groups are desirable, and chambers are available, the Elite makes these groups equally accessible.

*The Stereo Input
Module as subgroup
master*

One of the common applications of the Elite's unique Stereo Input Module is its use as a master module for returning a stereo subgroup to the main stereo mix. The first Stereo Input Module in the console has a switch labeled SUBGROUP 1-2 (the next SUBGROUP 3-4, etc.). When this switch is pressed, the input to the module becomes whatever stereo mix has been created on multitrack buses 1 and 2. The module offers stereo EQ and stereo/mono effects sends as well as full mute and solo functions and a stereo insert point in the patchbay. It also contains its own echo return function from the patch bay, for use with the group's dedicated chamber. This return provides level control of a true stereo effects signal or a panned mono input for a mono return. The module also provides a switch, labeled IN-PLACE DISABLE, which causes its Mix Pan SOLO switch to operate as a normal solo switch even though the master in-place mode is set up for other modules. But for this switch, using in-place solo on a subgroup master would cause its own group members to mute and thus mute the group itself.

The Stereo Input module

In addition to the standard microphone/line Input Module, the Elite offers an optional Stereo Input module with an associated high resolution stereo LED Peak/VU program meter. This full-featured module suits a number of applications involving the control of stereo input signals.

As a stereo line input

The most obvious application of the Stereo Input Module is to bring a line level stereo signal into the main stereo mix of the console. The source signal could be a two-track tape machine, video recorder, air signal monitor, or any other stereo source. To accommodate these applications, Elite consoles can be fitted with any desired number of Stereo Input modules. Gain trims on the left and right channels are provided for balancing inputs and these have enough range to accommodate quarter-track/half-track incompatibilities. Switches are provided to yield stereo, all right, all left, or mono operation. The module provides effects sends with stereo or mono sourcing, a stereo source output/module input insert point available in the patch bay, and a full-function logic controlled stereo mix mute. A four-band stereo equalizer is provided with fixed characteristics chosen for smooth and effective frequency response control. The output of the Stereo Input Module can be assigned to the multitrack buses as well as to the main stereo mix, allowing them to be subgrouped as well as sent to the multitrack recorder.

As a stereo echo return

Most modern echo chambers or processors are provided with stereo outputs, but most echo return modules accommodate only mono signals. The Elite's Stereo Input module is ideally suited for use as a stereo effects return. In addition to its return function, it provides sends to the echo buses for regenerative effects, and provides stereo EQ, a stereo solo function, and full assignability to multitrack and main stereo buses. An IN-PLACE DEFEAT switch prevents stereo solo of the module from causing an in-place solo action when the master section is set up for in-place solo; this would mute the sends to the chamber which was being returned to the module and would result in no signal.

As a stereo submaster module

The Stereo Input module is also designed for use as a stereo submaster module for subgroups created on the console's multitrack buses. In this application, which is discussed in the section of this operating guide on creating and controlling subgroups, the outputs of the first, second, third, and so forth, pairs of multitrack buses are brought to the first, second, and so on, of the Stereo Input modules through switches labeled SUBGROUP 1/2, SUBGROUP 3/4, etc, on successive Stereo Input modules.

Defeatism

A switch is provided to prevent the Stereo Input module's SOLO switch from causing in-place solo logic action, which would only mute the group members and their post-fader sends. The action of this IN-PLACE DEFEAT switch is automatic when the SUBGROUP switch is used, but should be actuated manually when the module is being used as a stereo echo return. The module also provides a stereo/mono echo return input with level control and pan pot to be used to return the echo signal from an echo chamber dedicated to the associated subgroup, making it unnecessary to use input modules solely for this purpose. Note that the Stereo Input module can be assigned to the multitrack buses as well as to the main stereo mix. This means that subgroups can be subgrouped, allowing, for example, a rhythm subgroup composed of strings subgroup, horns subgroup, and chorus subgroup, each having their own EQ and stereo compressor/limiter. The circuit design of the Stereo Input module has been approached so as to allow such uses without suffering buildup of noise or distortion. The availability of full logic mute functions also aids in more complex applications of the Elite's Stereo Input module. In all these operations, the console's design minimizes the use of patch cords, providing convenience and speeding resetup.

A summary of master section functions

On the surface, the master section of the Elite console appears to be simple, but its facilities are actually quite comprehensive. Some are unique to the Elite. This section summarizes those master section functions which have not been discussed elsewhere in this guide.

The cue mixer

The Elite provides a small mixer to generate the cue, foldback, or headphone signal for the performers in the studio. The cue-left and cue-right outputs have individual level controls and left/right stereo solo. In most cases the cue left and right mixes would simply be selected by switches in the cue mixer from the Auxiliary A and Auxiliary B mixes, respectively. If it is desired to add in an additional outside source, such as a click track or even a cassette player, this can be done by also selecting the PATCH switches and inserting this signal at the patch bay jack labeled CUE PATCH. Other switches add in the other auxiliary buses and the main stereo mix. The main stereo mix, rather than the monitoring mix, is chosen so that operator's use of solo functions will not disturb the performers. When the TALKBACK switch is pressed, the cue mix is reduced in level so that the talkback microphone signal is more easily heard in the headphones, an acknowledgement of the high headphone levels some artists prefer.

The cue mixer may also be used to combine auxiliary buses for other purposes, such as producing pre- and post-fader echo bus mixes into the same chamber feed. This application was mentioned previously in the section covering assignment of the insert, filter, and EQ.

Talkback to four-way cue mixes

Provision is made to talkback to all components of a four-way cue system. If, say, Aux A, Aux B, Aux 1, and Aux 2 were to be used to generate headphone cue mixes, Aux 1 and Aux 2 would be selected for inputs to the cue mixer. Their level of talkback signal would be determined by the CUE 1-2 TALKBACK LEVEL control. The outputs from Aux A and Aux B would be patched into the additional amplifier, and talkback level to Aux A and Aux B would be set with the AUX A-B TALKBACK LEVEL control. Talkback level to the slate function and to the studio speaker feed are also independently adjustable, and ON switches are provided for all four level controls so that levels may remain preset while the talkback is not being sent to the associated output.

Meter Selects

These switches allow the pair of needle-type VU meters to meter additional signals, as labeled. When selected to MONITOR, they will show the levels of soloed signals, but be cautious when interpreting the effect of the monitor MONO function on program or tones. Note that these meters can also meter the two mults (sets of parallel wired jacks) in the patch bay, permitting the meters to be patched about the console for critical monitoring purposes or to be used for signal tracing, level setting, or troubleshooting without additional equipment.

Oscillator

An amplitude leveled sine wave oscillator is provided with preset frequencies. This assures exact frequency and amplitude resetability when aligning equipment or slating master tapes for cutting. The 0VU switch assures exactly 4 dBu at the OSC OUT jack in the patch bay and at the multitrack and main stereo bus outputs when the bus trims are set to exactly unity gain. The TONES switch turns on the oscillator continuously but does not add in the talkback microphone signal, in contrast to the momentary SLATE switch. The TEST switch turns on the oscillator to the patch bay only, without causing the control room level to dim. In order to blow up the control room monitor amp and speakers with full level tones, the console operator must deliberately patch the OSC OUT signal in the bay to the C.R. EXTRA jacks and select CONTROL ROOM EXTRA for the control room source signal before turning up the control room level.

Control room level

The CONTROL ROOM LEVEL control of the Elite is custom made for Neotek with an element specifically designed for premium audio quality. We have even sold them to custom constructors whose megabuck consoles have made the covers of Mix and RE/P. Its element, like the custom designed elements of Neotek input faders, produces none of the I.M. distortion caused by controls with conductive plastic elements. This degree of IM distortion would be more than ten times greater than that produced by the console electronics. The control has thirty gentle detents to facilitate resetting to specific monitoring levels. Furthermore, the stereo tracking accuracy of this computer trimmed control is far better over a far wider range than any other commercially available controls, insuring that no shift of the stereo image takes place with changes in level.

Bits and pieces

The studio ON switch, when not pressed, shorts the studio amp inputs to ground to prevent any leakage from the console or pickup of radio frequency interference (note, however, that power amps also pick up interference from their output cables as well as their inputs). The same is true for the unselected control room amp/speaker combinations on the A SPEAKER, B SPEAKER, C SPEAKER switches (note that these A,B,C references have nothing whatever to do with mute groups A, B, C). The CONTROL ROOM source select switches TAPE 1 through TAPE 4 provide balanced stereo inputs from any types of sources. Additional sources may be patched in using the stereo C.R. EXTRA jacks in the bay and selecting EXTRA as the control room source. An EXTRA input is also provided for the studio source signal. The MONO switch effects only the control room signal and will reduce the level of mono left or mono right signals by 6 dB but will not effect the level of identical phase coherent left and right signals. Mono is actuated both manually by a switch and automatically during solo of a mono signal. The DIM switch, which is also logic actuated by TALKBACK, SLATE, or TONES functions, reduces the level of the control room signal to prevent acoustical feedback or to allow conversations in the control room without loss of monitoring reference.

Danger Will Robinson

The feed to the studio level control which occurs when CONTROL ROOM TO STUDIO is pressed will be the same as the input that has been selected for the control room. It will not be affected by the solo or mono functions. It will also not be affected by the dim function. This means that if this switch is pressed and tones are put on the stereo mix, it is possible to be blasting the studio speakers and not realize it in the control room. We strongly recommend that this switch be pressed only while its function is needed and that it not be left normally latched. We have placed a red warning LED next to it.

Direct outputs and bus outputs beyond 26

The Elite provides metered, balanced outputs on multitrack buses 1 through 26, with buses 25 and 26 intended for use as a second stereo bus. Modules 27 and up have their bus output circuits configured as balanced, post-fader and post-TRACK MUTE direct outputs, which are accessible in the patch bay. Note that if BUS is selected for the input module channel, Fader or Monitor, which is feeding the tracks, a feedback path will be created and oscillation will result if the fader is up. This can also occur if both of the two selection switches are pressed and the wrong switch is released first, leaving BUS pressed. This situation is a necessary consequence of the routing flexibility of the Elite and the requirement that input modules be interchangeable.

Circuit design philosophy of the Elite

Neotek was the first manufacturer to offer transformerless consoles, including transformerless mic preamps, preceding others by many years. Since those first consoles Neotek has become well known for the performance it has been able to wring out of op amp circuits by using proprietary topologies and skillful circuit board layout. Technicians often comment that somehow Neotek circuits have more components but produce less noise and distortion than products from other manufacturers. The unique non-op amp circuits which Neotek has developed for the Elite take this level of performance an order of magnitude farther.

The challenge of digital audio to analog design

The digital creation and digital recording of signals that is becoming common in modern studios places extraordinary demands on console circuit designs. Neotek's commitment to producing consoles for esoteric digital audiophile recording, where the finest capacitor microphones are used, has proven the advantage of unique topologies, wideband circuit design, and circuit board layout according to radio frequency design rules. The ability of digital synthesizers to produce full level signals from subsonic to ultrasonic frequencies is, in many respects, even more demanding.

The non-op amp solution

Neotek's design engineers have for some years been researching non-op amp circuit topologies in the belief that they were often better suited to producing optimum sonic performance in demanding applications. Operational amplifiers, integrated or discrete, are convenient building blocks for analog signal processing which seduce designers by seeming to offer easy routes to satisfactory circuit performance. In fact this is not the case; application specific circuits, while far more difficult to design, can offer substantially better performance than cook book circuits made with op amps. Superior audio quality does not result from perusing op amp data sheets, but from having the design skills to create the optimum topology for each unique application.

Hybrid circuits in the Elite

To transcend the limitations of integrated op amps, all critical gain stages of the Elite are composed of hybrid circuits. These stages include the microphone preamplifiers, fader buffers, and track combining amps. Remember that the minimum path design of the Elite's Input Modules means that only these circuits are in the signal paths when the other functional elements are unassigned. This is one of the reasons that the Elite is the cleanest sounding console presently available.

How do they do it?

Neotek hybrid circuits are combinations of discrete transistors and integrated amplifiers in which the discrete transistors form the critical, performance determining input stage of the circuit and the integrated amplifiers are relegated to carefully loaded output chores. This is not the more common hybrid approach, in which op amps determine the audio performance and discrete transistors are used to raise the power supply voltage capability. Such circuits have resulted in nasty sounding consoles and have been discarded by most manufacturers. Neotek's approach is unique. For example, its microphone preamp was developed to minimize Early effect in the gain devices because this distortion contribution cannot easily be reduced by feedback. This effect is virtually unknown to other console designers, who generally confuse it with Miller effect. Circuits which eliminate Early effect and modulation of Miller effect, improving to the performance of Neotek gain stages, are possible with hybrid designs, but not with integrated op amps, whose circuits are essentially fixed. Neotek designers create unique hybrid topologies whenever this will improve performance.

The most critical stages are the most complex

Modern recording methods and synthesized virtual tracks create the potential for a very high number of summed inputs to the main stereo mix. This places exceptional demands on the stereo master circuits which must process these signals without adding noise or distortion. To accommodate this on the Elite, the main stereo combining amp employs an innovative circuit using complementary symmetry devices operating in Class A mode with no voltage changes on any of their terminals and with 0 collector-emitter voltage. The associated integrated amplifier is operated with 0 common mode voltage as well. Circuits of this sophistication have never before been used in recording console design. This reduces all forms of static and dynamic distortion, along with sensitivity to bus input effects, to the absolute minima. To preserve this performance, the stereo master fader buffers and monitor master fader buffers are servoed Class A discrete circuits. This is because unity gain non-inverting amplifiers present daunting problems for op amps in that 100% of the signal is common mode. In fact, all such circuits have been eliminated from the Elite for reasons of maximum sonic performance. Even the unity gain buffer in the control room monitor chain is a Class A discrete design. It might be mentioned that the combination of the performance of the Elite's stereo master circuits and its unique mute circuit design means that the residual output noise of the stereo master is extraordinarily low. This is especially noticeable in a mixing session when only a few inputs of a large console are unmuted and low noise digital recorders are being used.

Ultrawide bandwidth circuits have always been part of the design philosophy at Neotek. Circuit boards are laid out, using a Hewlett Packard CAD system which is the most sophisticated in the industry, according to radio frequency principles in acknowledgement that the amplifiers have small signal open loop bandwidths in the tens of Megahertz. Every amplifier stage that Neotek uses runs at full large signal bandwidth, with the small signal bandwidth limited to lower ultrasonic frequencies. In this manner, slew induced, or TIM, distortion is eliminated. The trick is to maintain full large signal bandwidth through many stages with complete stability. To this end, other manufacturers use decompensation which reduces slew rate unacceptably. For example, one common British console priced comparably to the Elite a measured maximum slew rate of 3.3 volts per microsecond. This is less than a fourth that of the Elite (which is presently the fastest production console) and about half that of other contemporary consoles. A popular rule of thumb for high quality audio suggests that this console could produce only about +12 dBu at high frequencies without objectionable sonic degradation, or equivalently only about 10 kHz at full level without slew induced distortion. This is loss of an octave at the high end is inadequate for modern studios and especially for digital recording techniques. The Elite produces full output well beyond 20 kHz with no trace of slew induced anomalies.

What does it all mean?

The objective of console design should not be the production of impressive specifications; these come as the natural consequence of designing for maximum sonic performance. The specifications which are most meaningful to sonic performance are unknown to, or closely guarded by, console manufacturers and are seldom seen on data sheets. Perhaps this is just as well, because few standards exist for obtaining or comparing such specifications.

As has been emphasized, Neotek design engineers recognized that modern studios and digital recording present unusual problems for consoles. Bluntly, consoles must gently and unobtrusively handle some pretty nasty signals. Standard op amp circuits, much like digital audio circuits, produce good specifications (when measured individually) up to close to clipping and then obnoxious garbage thereafter. This odd harmonic garbage radiates into other signals throughout the module and the console through power supplies, adjacent circuit board traces, and grounds. The result is the nasty sound for which op amps have rightly become famous and which compounds the problems of "digital sound".

The Neotek design objective

In contrast, Neotek consoles have become known for superior overall sonic performance as well as outstanding specifications. The hybrid circuits in the Elite were designed to have low distortion, but distortion which is composed of low order even harmonics. Circuits are exceptionally well isolated, both intra- and inter-modules, and power supplies are extensively bypassed and decoupled to achieve not only exceptionally low crosstalk, but also freedom from sonic haze resulting from spurious ultrasonic and radio frequency signals.

Can we talk?

In the age of microprocessors it might seem an anachronism to admit candidly that the basic circuit design objective of the Elite was to create a console sound that emulated aspects of the performance of the best vacuum tube electronics. We wanted the clarity and musical definition which the finest vacuum tube circuits seem to lend to middle frequencies of even the most demanding signals, but we wanted to extend this performance to subsonic and ultrasonic frequencies as well. We wanted the apparently effortless handling of wide dynamic range material without the feeling of compression at high levels or loss of inner detail at low levels within a complex mix. We wanted to create electronics that would treat digital signals and digital recorders with such compassion that the signals would actually sound better for having passed through the console.

The proof, as they say, is in the pudding

If these objectives had not been met there would be little satisfaction in the enthusiasm with which the operating architecture of the Elite has been received or the fact that experienced technicians believe they have measured the noise floor of the Elite at below the theoretical minimum. In fact, however, in direct comparisons the most critical listeners have consistently proclaimed the Elite as the best sounding console presently available at any price. New England Digital has chosen the Elite for its training suites and trade show demonstrations because, as they say, it makes the Synclavier sound its best. Stevie Wonder, an artist with impeccable sonic judgement and no constraints on cost, has purchased an Elite for his personal use. The list of confirming evidence goes on, and the message is clear.

DDI, MIDI Direct, and automation

Modern recording facilities face a variety of interface requirements. They may be required to communicate with video editors, MIDI sequencers, and computers or controllers of many kinds. The traditional solution has been to use automation for every such purpose, but this is often inadequate and not cost effective. The Elite offers other options in addition to automation.

Logic controlled mutes

The Talkback, Slate, and Dim functions of the Elite are logic controlled and may be actuated by remote switches. In a similar way, the Input Module mute function and the master section's MUTE A, MUTE B, and MUTE C mute group masters are also logic controlled and optional provisions of several kinds are available to control them from remote functions as simple as switches or as complex as computers. The remote function operates like a one-line master group in that it can turn the module off if it is on, but not on if it has been locally turned off. The silent, ramped performance of the Neotek mute circuit is uncompromised by remote logic control.

DDI

The optional Direct Digital Interface feature of the Elite provides an optocoupler isolated logic level input to each Input Module mute and to each of the three mute group masters. These inputs are made available on a Centronics-type rear panel connector. They may be directly connected to the General Purpose Interface (GPI) lines of video editors, to the parallel output logic lines of digital synthesizers such as the Synclavier, or they may be connected directly to any type of computer controller, composer, or editor. This permits direct low cost software control of the input module mutes so that they may be locked to MIDI, SMPTE, or a music composition computer, and follow remote editing changes without attention.

MIDI Direct

This optional feature was designed for the Elite by Jim Cooper of JLC Cooper in cooperation with Neotek and the Stevie Wonder/Wonderland group. In combination with any separate sequencer it permits reading, writing, editing, and storage of the mute functions of the Elite referenced to MIDI. This is literally MIDI-based mute automation, and it provides most of the benefits of conventional automation at a fraction of the cost. For a MIDI oriented studio, this feature is far less cumbersome than tape or floppy based automation and integrates the Elite's functions into the familiar realm of MIDI sequencer editing commands as well as associating the mute functions with musically related points in the score. For time-related positioning of mute/edit points, we recommend JLC Cooper's inexpensive SAM unit; this provides MIDI Direct with SMPTE-based mute/edit points and adds editing power as well as floppy disk storage of all data. SAM requires no modifications to MIDI Direct, it just replaces the associated sequencer. MIDI Direct operation requires no knowledge of music, no direct use of MIDI, and no computer expertise.

Automation

Neotek has concentrated its design efforts in high performance analog circuitry and has left automation to digital specialists. At the same time, the separate and removable fader panel associated with each Input Module in combination with the fact that internal signals in Neotek consoles are at uniform professional line level makes it easy to fit, retrofit, or update any automation system, including moving fader systems. The Elite has been designed so that the presence of well-designed digital circuits within its frame will not impair its performance. Neotek can provide factory installed automation from OptiMix, Audio Kinetics, Digital Creations VCA and moving fader systems, George Massenberg Laboratories, and Martinsound Flying Faders.

Operating instructions for each of these features are supplied in separate manuals when the respective option is ordered.